

AUS90

UNDER SINK GREASE ARRESTOR PUMP STATION

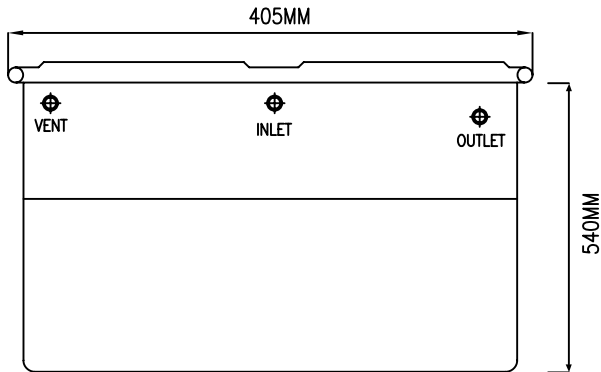

STANDARD FEATURES:

- 40MM PRESSURE UNION
- 40MM PRESSURE OUTLET
- 50MM DWV INLET
- 50MM DWV VENT
- SUBMERSIBLE VORTEX PUMP
- NON-RETURN VALVE

OPTIONAL EXTRAS:

- HIGH LEVEL ALARMS

APPLICATIONS:

- TAKEAWAY / HOT FOOD SHOPS
- BAKERIES
- SMALL RESTAURANTS ETC

TO BE USED WITH KITCHEN WASTE UP TO
1000 L/Hr IN CONJUNCTION WITH A
GREASE ARRESTOR

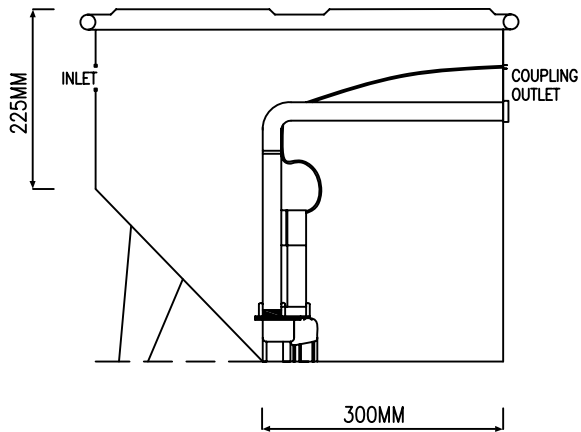

WORKING CAPACITY 85L
MAXIMUM CAPACITY 95L

AUSTRALIAN STANDARDS

AS1170-P1
AS2634
AS1546

THIS DOCUMENT IS CONFIDENTIAL. THE COPYRIGHT THEREIN IS VESTED IN AGLASS PTY LTD KIRRAWEE, NSW, AUSTRALIA. RECIPIENTS MUST OBTAIN THE WRITTEN AUTHORITY OF THE SAID COMPANY BEFORE WHOLLY OR PARTLY DUPLICATING THE CONTENTS OR DISCLOSING SAME TO OTHERS. ALL RIGHTS RESERVED.

	SIGNATURE	DATE
DRAWN	JK	28-01-09
CHECKED	KA	28-01-09
APPR'D	KA	28-01-09
DRAWING NUMBER:		REV 0
SCALE:	NTS	SHEET SIZE A4

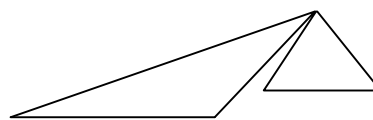

PH (02) 9542 6511
FAX (02) 9542 6561
EMAIL info@aglass.com.au
WEB www.aglass.com.au
AGLASS PTY LTD